

Ball Valves and Pneumatic Ball Valves

10B Series: 10,000 psig (690 bar)

15B Series: 15,000 psig (1034 bar)

20B Series: 20,000 psig (1379 bar)

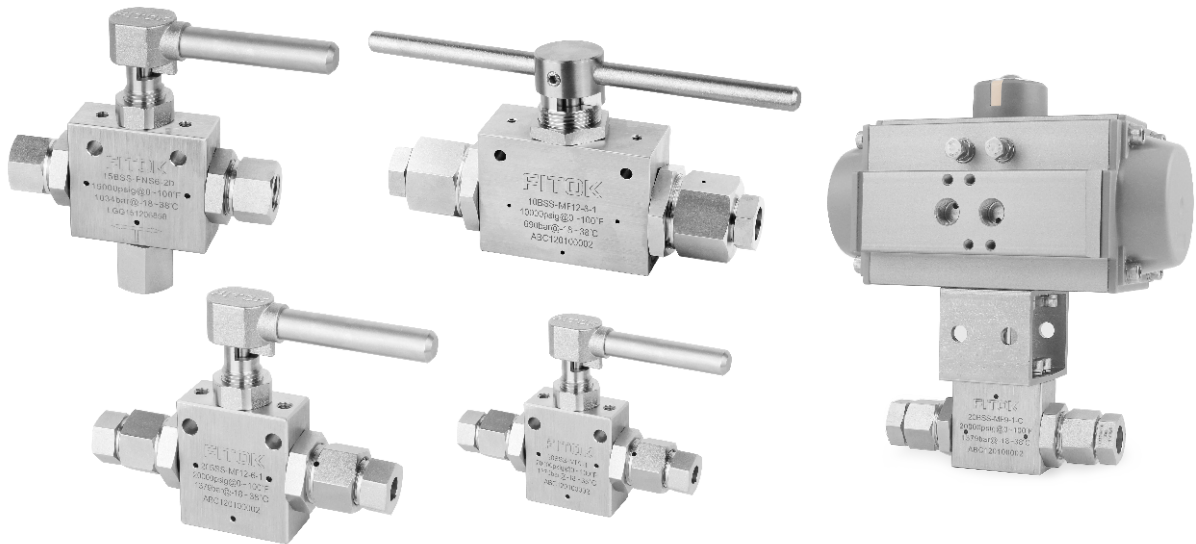

Fittings

Tubing

Quick Couplings

Line Filters

Valves

Sour Service Products

Subsea Valves

Part Number Crossover Charts

Contents

Features	E-04
Working Pressure at Ambient Temperature	E-04
Pressure vs. Temperature Curve	E-04
Flow Configuration	E-04
Standard Materials of Construction	E-05
Dimensions	E-07
Panel Mounting Dimensions	E-07
Ordering Information and Dimensions	E-08
Ordering Number Description	E-10

Fittings

Tubing

Quick Couplings

Line Filters

Valves

Sour Service Products

Subsea Valves

Part Number Crossover Charts

Features

- Working pressure up to 20,000 psig (1379 bar)
- Fluorocarbon FKM O-ring for operation from 0°F to 400°F (-17.8°C to 204°C); other O-ring materials available
- PEEK seats offer excellent resistance to chemicals, heat and abrasion
- Trunnion mounted stem design
- Full-port flow path to minimize pressure drop
- 2-way and 3-way valve configurations optional, with bidirectional flow for 2-way valves
- Pneumatic actuator optional with air pressure from 80 psig to 116 psig (5.5 bar to 8 bar)

Working Pressure at Ambient Temperature

Flow Pattern	Orifice		Working Pressure ^① psig (bar)
	Designator	Dimensions, in. (mm)	
2-Way	4	0.25 (6.35)	20,000 (1379)
	6	0.375 (9.5)	20,000 (1379)
	8	0.5 (12.7)	15,000 (1034)
3-Way	4	0.19 (4.8)	20,000 (1379)
	6	0.33 (8.3)	15,000 (1034)
	8	0.5 (12.7)	10,000 (690)

① The working pressure of NPT connections 1/2" or under is 15,000 psig (1034 bar), while that of NPT connections over 1/2" is 10,000 psig (690 bar).

Pressure vs. Temperature Curve

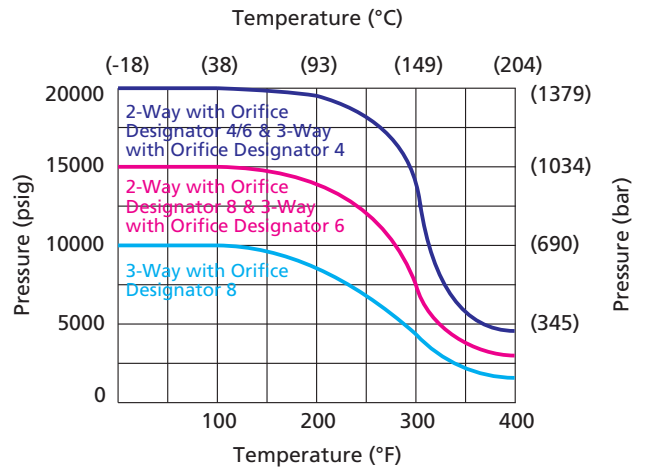

Flow Configuration

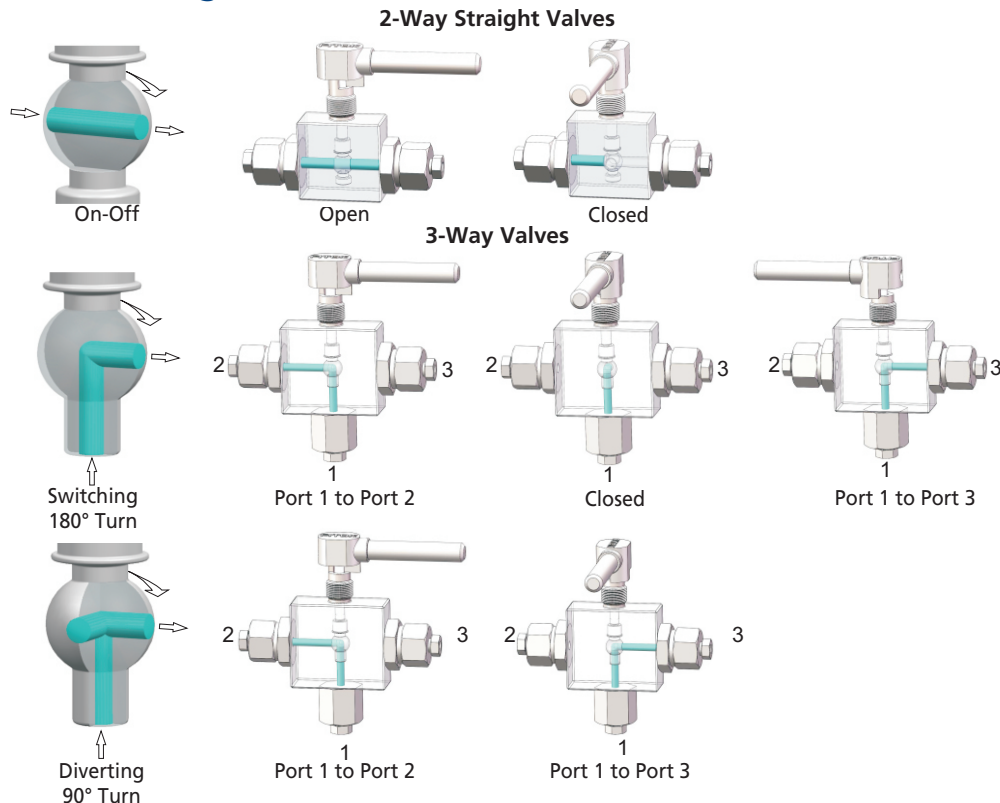

Note: The side connection is not allowed to work as inlet.

Standard Materials of Construction

2-Way Straight Valves

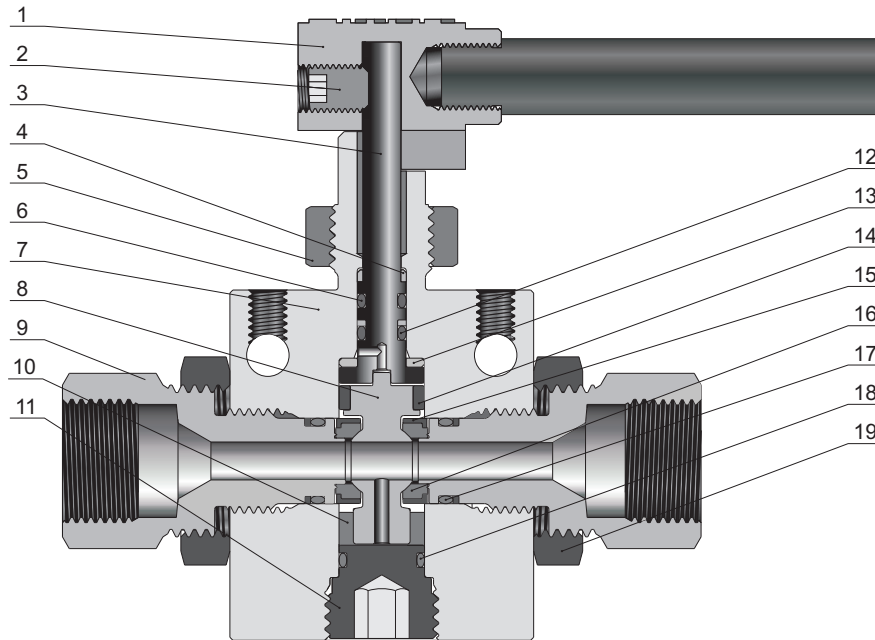

Item	Component	Material Grade
1	Handle	Stainless Steel
2	Set Screw	Stainless Steel
3	<i>Stem</i>	<i>316 SS</i>
4	Stem Backup	PEEK
5	Panel Nut	316 SS
6	Stem O-Ring	Fluorocarbon FKM
7	<i>Body</i>	<i>316 SS</i>
8	<i>Ball</i>	<i>316 SS</i>
9	<i>Seat Gland</i>	<i>316 SS</i>
10	<i>Ball Bearing</i>	<i>PEEK</i>
11	<i>Plug</i>	<i>316 SS</i>
12	<i>Stem O-Ring</i>	<i>Fluorocarbon FKM</i>
13	<i>Thrust Washer</i>	<i>PEEK</i>
14	<i>Ball Bearing</i>	<i>PEEK</i>
15	<i>Seat Retainer</i>	<i>316 SS</i>
16	<i>Seat</i>	<i>PEEK</i>
17	<i>Seat Gland O-Ring</i>	<i>Fluorocarbon FKM</i>
18	<i>Plug O-Ring</i>	<i>Fluorocarbon FKM</i>
19	Lock Nut	316 SS
	Lubricant	Molybdenum Disulfide/Fluorinated-Based

Wetted components listed in italics.

Fittings

Tubing

Quick Couplings

Line Filters

Valves

Sour Service Products

Subsea Valves

Part Number Crossover Charts

Fittings
Tubing
Quick Couplings
Line Filters
Valves
Sour Service Products
Subsea Valves
Part Number Crossover Charts

3-Way Valves

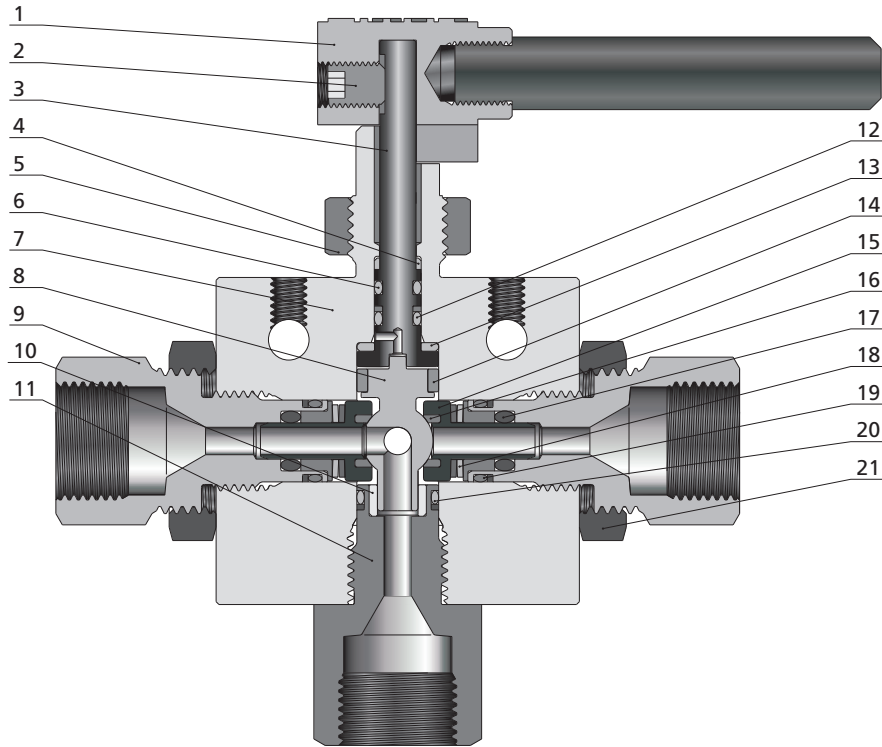

Item	Component	Material Grade
1	Handle	Stainless Steel
2	Set Screw	Stainless Steel
3	Stem	316 SS
4	Stem Backup	PEEK
5	Panel Nut	316 SS
6	Stem O-Ring	Fluorocarbon FKM
7	<i>Body</i>	<i>316 SS</i>
8	<i>Ball</i>	<i>316 SS</i>
9	<i>Seat Gland</i>	<i>316 SS</i>
10	<i>Ball Bearing</i>	<i>Copper Alloy</i>
11	<i>Bottom Gland</i>	<i>316 SS</i>
12	<i>Stem O-Ring</i>	<i>Fluorocarbon FKM</i>
13	<i>Thrust Washer</i>	<i>PEEK</i>
14	<i>Ball Bearing</i>	<i>PEEK</i>
15	<i>Seat Retainer</i>	<i>S17400</i>
16	<i>Seat</i>	<i>Carbon Filled PEEK</i>
17	<i>Seat Retainer O-Ring</i>	<i>Fluorocarbon FKM</i>
18	<i>Bellville Washer</i>	<i>S17700</i>
19	<i>Seat Gland O-Ring</i>	<i>Fluorocarbon FKM</i>
20	<i>Bottom Gland O-Ring</i>	<i>Fluorocarbon FKM</i>
21	Lock Nut	316 SS
	Lubricant	Molybdenum Disulfide/Fluorinated-Based

Wetted components listed in italics.

Dimensions

2-Way Straight Valves

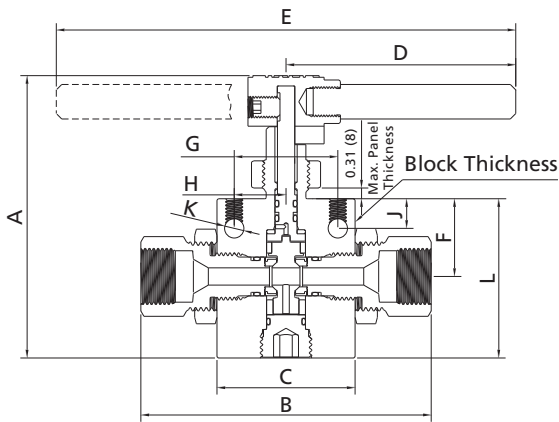

3-Way Valves

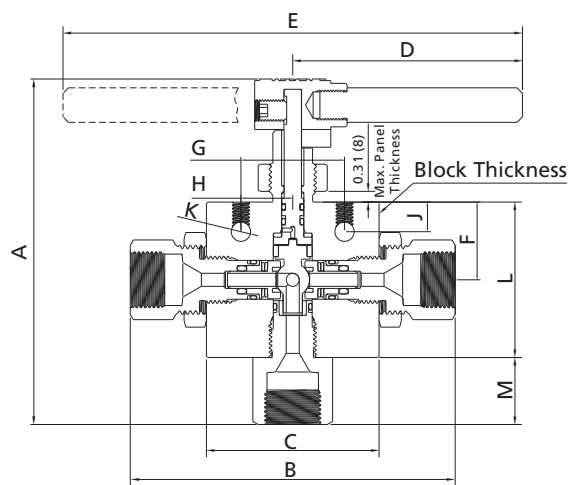

Flow Pattern	Orifice Designator	Dimensions, in. (mm)												Block Thickness
		A	B	C	D	E	F	G	H	J	K	L	M	
2-Way	4	4.09 (103.9)	4.19 (106.5)	2.00 (50.8)	3.33 (84.5)	/	1.13 (28.6)	1.50 (38.1)	0.75 (19.1)	0.43 (10.9)	0.28 (7.1)	2.31 (58.6)	/	1.00 (25.4)
	6	4.84 (121.0)	5.53 (140.3)	3.00 (76.2)	4.96 (126.0)	/	1.38 (34.9)	2.00 (50.8)	1.00 (25.4)	0.41 (10.3)	0.28 (7.1)	2.95 (74.9)	/	1.38 (34.9)
	8	5.39 (136.8)	7.73 (196.5)	4.12 (104.6)	/	10.25 (260.0)	1.66 (42.2)	3.00 (76.2)	1.50 (38.1)	0.50 (12.7)	0.28 (7.1)	3.52 (89.4)	/	1.75 (44.5)
3-Way	4	5.00 (127.0)	4.70 (119.5)	2.50 (63.5)	3.33 (84.5)	/	1.13 (28.6)	1.50 (38.1)	0.75 (19.1)	0.43 (10.9)	0.28 (7.1)	2.25 (57.2)	0.48 (12.3)	1.00 (25.4)
	6	5.88 (149.3)	5.53 (140.3)	3.00 (76.2)	4.96 (126.0)	/	1.38 (34.9)	2.00 (50.8)	1.00 (25.4)	0.41 (10.3)	0.28 (7.1)	2.87 (73.0)	1.89 (30.2)	1.38 (34.9)
	8	6.91 (175.6)	7.77 (197.4)	4.12 (104.6)	/	10.25 (260.0)	1.66 (42.2)	3.00 (76.2)	1.50 (38.1)	0.50 (12.7)	0.28 (7.1)	3.34 (84.9)	1.70 (43.2)	1.75 (44.5)

Note: All dimensions are for reference only and are subject to change.

Panel Mounting Dimensions

Flow Pattern	Orifice Designator	Dimensions, in. (mm)			
		A	B	C	D
2-Way	4	1.50 (38.1)	0.75 (19.1)	0.75 (19.1)	0.28 (7.1)
	6	2.00 (50.8)	1.00 (25.4)	1.13 (28.6)	0.28 (7.1)
	8	3.00 (76.2)	1.50 (38.1)	1.44 (36.5)	0.28 (7.1)
3-Way	4	1.50 (38.1)	0.75 (19.1)	0.75 (19.1)	0.28 (7.1)
	6	2.00 (50.8)	1.00 (25.4)	1.13 (28.6)	0.28 (7.1)
	8	3.00 (76.2)	1.50 (38.1)	1.44 (36.5)	0.28 (7.1)

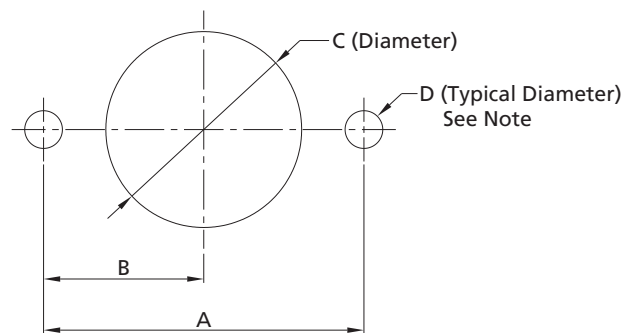

Notes: 1. Body mounting 1/4-20 thread.
2. All dimensions are for reference only and are subject to change.

Fittings
Tubing
Quick Couplings
Line Filters
Valves
Sour Service Products
Subsea Valves
Part Number Crossover Charts

Ordering Information and Dimensions

Flow Pattern	Orifice Designator	Connection	Orifice Size in. (mm)	Cv	Ordering Number	Working Pressure psig (bar)	
2-Way	4	FNS2	0.25 (6.35)	1.51	15BSS-FNS2-4-1	15,000 (1034)	
		FNS4	0.25 (6.35)	1.51	15BSS-FNS4-4-1		
		FNS6	0.25 (6.35)	1.51	15BSS-FNS6-4-1		
		FNS8	0.25 (6.35)	1.51	15BSS-FNS8-4-1		
		DFF2	0.094 (2.4)	0.16	15BSS-DFF2-4-1	20,000 (1379)	
		DFF4	0.19 (4.8)	0.82	20BSS-DFF4-4-1		
		DFF6	0.25 (6.35)	1.51	20BSS-DFF6-4-1		
		DFF8	0.25 (6.35)	1.51	20BSS-DFF8-4-1		
	MF4	0.11 (2.8)	0.23	20BSS-MF4-4-1	20,000 (1379)		
	MF6	0.2 (5.2)	0.98	20BSS-MF6-4-1			
	MF9	0.25 (6.35)	1.51	20BSS-MF9-4-1			
	HF4	0.094 (2.4)	0.16	20BSS-HF4-4-1			
	HF6	0.125 (3.2)	0.32	20BSS-HF6-4-1	15,000 (1034)		
	HF9	0.19 (4.8)	0.82	20BSS-HF9-4-1			
	6	FNS4	0.375 (9.5)	3.51		15BSS-FNS4-6-1	15,000 (1034)
		FNS6	0.375 (9.5)	3.51		15BSS-FNS6-6-1	
FNS8		0.375 (9.5)	3.51	15BSS-FNS8-6-1			
DFF8		0.375 (9.5)	3.51	20BSS-DFF8-6-1	20,000 (1379)		
DFF9	0.375 (9.5)	3.51	20BSS-DFF9-6-1				
MF6	0.2 (5.2)	0.98	20BSS-MF6-6-1				
MF9	0.31 (7.9)	2.36	20BSS-MF9-6-1				
MF12	0.375 (9.5)	3.51	20BSS-MF12-6-1	10,000 (690)			
8	FNS12	0.5 (12.7)	6.31		10BSS-FNS12-8-1	10,000 (690)	
	FNS16	0.5 (12.7)	6.31		10BSS-FNS16-8-1		
	DFF12	0.5 (12.7)	6.31		15BSS-DFF12-8-1	15,000 (1034)	
	MF12	0.5 (12.7)	6.31	15BSS-MF12-8-1			
MF16	0.5 (12.7)	6.31	15BSS-MF16-8-1				
3-Way	4	FNS2	0.19 (4.8)	0.5	15BSS-FNS2-4-2	15,000 (1034)	
					15BSS-FNS2-4-2D		
		FNS4	0.19 (4.8)	0.5	15BSS-FNS4-4-2		15BSS-FNS4-4-2D
		FNS6	0.19 (4.8)	0.5	15BSS-FNS6-4-2		15BSS-FNS6-4-2D
		FNS8	0.19 (4.8)	0.5	15BSS-FNS8-4-2		15BSS-FNS8-4-2D
	DFF2	0.094 (2.4)	0.13	15BSS-DFF2-4-2	15BSS-DFF2-4-2D		
	DFF4	0.19 (4.8)	0.5	20BSS-DFF4-4-2	20BSS-DFF4-4-2D		
	DFF6	0.19 (4.8)	0.5	20BSS-DFF6-4-2	20BSS-DFF6-4-2D		
	DFF8	0.19 (4.8)	0.5	20BSS-DFF8-4-2	20BSS-DFF8-4-2D		
MF4	0.11 (2.8)	0.17	20BSS-MF4-4-2	20BSS-MF4-4-2D			
MF6	0.19 (4.8)	0.5	20BSS-MF6-4-2	20BSS-MF6-4-2D			
MF9	0.19 (4.8)	0.5	20BSS-MF9-4-2	20BSS-MF9-4-2D			

Ordering Information and Dimensions (continued)

Flow Pattern	Orifice Designator	Connection	Orifice Size in. (mm)	Cv	Ordering Number	Working Pressure psig (bar)
3-Way	4	HF4	0.094 (2.4)	0.13	20BSS-HF4-4-2	20,000 (1379)
					20BSS-HF4-4-2D	
		HF6	0.125 (3.2)	0.22	20BSS-HF6-4-2	
					20BSS-HF6-4-2D	
		HF9	0.19 (4.8)	0.5	20BSS-HF9-4-2	
					20BSS-HF9-4-2D	
	6	FNS4	0.33 (8.3)	2.1	15BSS-FNS4-6-2	15,000 (1034)
					15BSS-FNS4-6-2D	
		FNS6	0.33 (8.3)	2.1	15BSS-FNS6-6-2	
					15BSS-FNS6-6-2D	
		FNS8	0.33 (8.3)	2.1	15BSS-FNS8-6-2	
					15BSS-FNS8-6-2D	
		DFF8	0.33 (8.3)	2.1	15BSS-DFF8-6-2	
					15BSS-DFF8-6-2D	
		DFF9	0.33 (8.3)	2.1	15BSS-DFF9-6-2	
					15BSS-DFF9-6-2D	
		MF6	0.2 (5.2)	0.81	15BSS-MF6-6-2	
					15BSS-MF6-6-2D	
	MF9	0.31 (7.9)	1.9	15BSS-MF9-6-2		
				15BSS-MF9-6-2D		
	MF12	0.33 (8.3)	2.1	15BSS-MF12-6-2		
				15BSS-MF12-6-2D		
	8	FNS12	0.5 (12.7)	4.4	10BSS-FNS12-8-2	10,000 (690)
					10BSS-FNS12-8-2D	
FNS16		0.5 (12.7)	4.4	10BSS-FNS16-8-2		
				10BSS-FNS16-8-2D		
MF12		0.5 (12.7)	4.4	10BSS-MF12-8-2		
				10BSS-MF12-8-2D		
MF16	0.5 (12.7)	4.4	10BSS-MF16-8-2			
			10BSS-MF16-8-2D			

Fittings
Tubing
Quick Couplings
Line Filters
Valves
Sour Service Products
Subsea Valves
Part Number Crossover Charts

Ordering Number Description

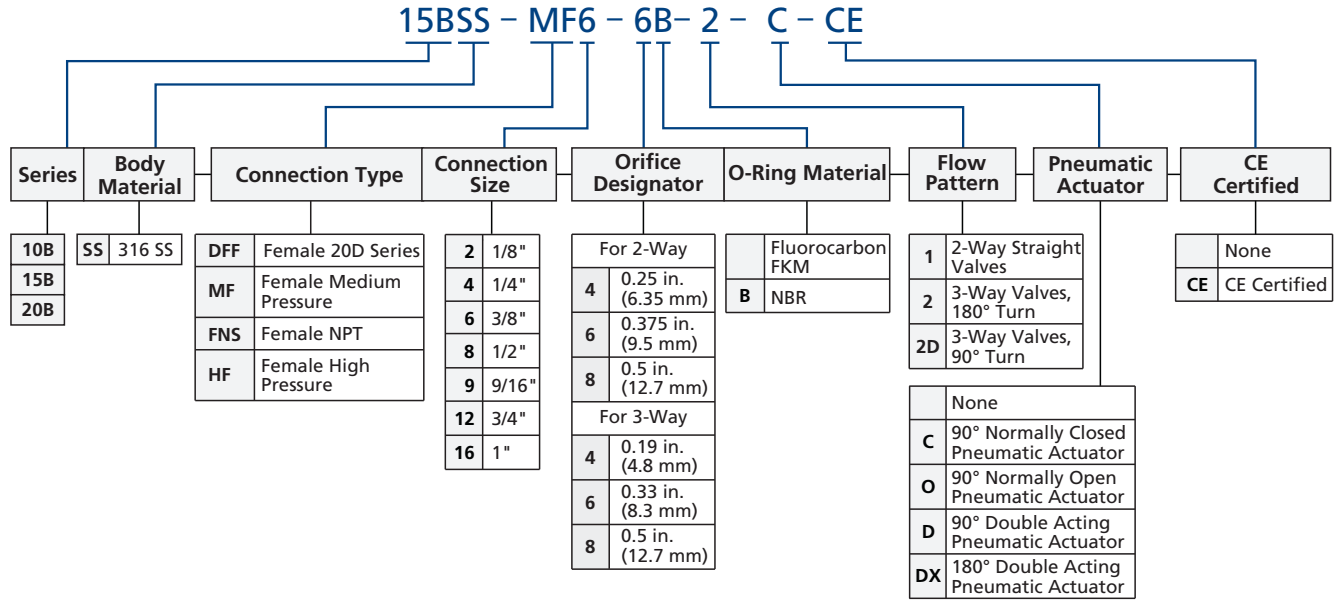

Designator	O-Ring Material	Working Temperature Range, °F (°C)
	Fluorocarbon FKM	0 to 400 (-17.8 to 204)
B	NBR	-10 to 250 (-23 to 121)

- Notes: 1. For more details regarding 20D Series and Medium/High Pressure connections, please see **Connection Information** on A-02.
2. "Ordering Number Description" is a reference to understand the combination rules of FITOK product part number. Not all combinations are available.